



SIN 337

Issue 2.3
March 2009

Suppliers' Information Note

For The BT Network

BT MegaStream 622, BT MegaStream Aggregate (STM4) Service Description

Each SIN is the copyright of British Telecommunications plc. Reproduction of the SIN is permitted only in its entirety, to disseminate information on the BT Network within your organisation. You must not edit or amend any SIN or reproduce extracts. You must not remove BT trade marks, notices, headings or copyright markings.

This document does not form a part of any contract with BT customers or suppliers.

Users of this document should not rely solely on the information in this document, but should carry out their own tests to satisfy themselves that terminal equipment will work with the BT network.

BT reserves the right to amend or replace any or all of the information in this document.

BT shall have no liability in contract, tort or otherwise for any loss or damage, howsoever arising from use of, or reliance upon, the information in this document by any person.

Due to technological limitations a very small percentage of customer interfaces may not comply with some of the individual characteristics which may be defined in this document.

Publication of this Suppliers' Information Note does not give or imply any licence to any intellectual property rights belonging to British Telecommunications plc or others. It is your sole responsibility to obtain any licences, permissions or consents which may be necessary if you choose to act on the information supplied in the SIN.

This SIN is available in Portable Document Format (pdf) from: <http://www.sinet.bt.com/index.htm>

Enquiries relating to this document should be directed to: help@sinet.bt.com

CONTENTS

1. INTRODUCTION.....	3
2. SERVICE OUTLINE	3
2.1 GENERAL	3
2.2 MEGASTREAM 622 POINT TO POINT	3
2.3 MEGASTREAM AGGREGATE (STM4).....	3
3. SERVICE AVAILABILITY	3
4. TECHNICAL SPECIFICATION.....	4
4.1 SERVICE PRESENTATION	4
FIGURE 1 - COMPARISON OF SDH PATH VS. SECTION.....	4
4.2 CONNECTION CHARACTERISTICS	5
4.3 MULTIPLEX SECTION PROTECTION (MSP).....	5
5. FURTHER INFORMATION CONTACT POINT.....	5
6. REFERENCES.....	5
7. ABBREVIATIONS	6
8. HISTORY	6

1. Introduction

This Suppliers' Information Note (SIN) describes the BT MegaStream 622 and MegaStream Aggregate (STM4) services and provides technical information for terminal equipment (TE) manufacturers and suppliers. It should be read in conjunction with SIN333, SDH Customer Interfaces At the STM-N level (where N=1,4,16).

Note: Whilst still supported for existing customers, MegaStream 622 is withdrawn for new sale.

2. Service Outline

2.1 General

BT STM4 is an inland Synchronous Digital Hierarchy (SDH) point to point or aggregate (MegaStream Aggregate) leased high speed digital service supporting customer access at 622Mbit/s which conforms to ITU-T Recommendation G.707^[1].

2.2 MegaStream 622 Point to Point

The service will support the bandwidth provided by four concatenated VC4 SDH Virtual Containers. The use of the STM4 will depend on customer application. The service is available to the customer via the following interface:

- ITU-T Recommendation G.957^[2] (STM-4 optical)

2.3 MegaStream Aggregate (STM4)

The MegaStream Aggregate (STM4) service allows for multiple numbers of inland MegaStream 2048Kbit/s circuits or a combination of MegaStream 2048Kbit/s, 34,368Kbit/s and 45,736Kbit/s, 149,760Kbit/s, or KiloStream Aggregate Interface Bearer, International Private Circuits, ISDN 30 or any other 2Mbit/s presentation as per the multiplexing structure in figure 1 of ETS 300 147^[3] possibly from all over the United Kingdom; to be delivered to a site as a single 622,080Kbit/s customer presentation. The service will support a maximum of 252 Customer useable individual 2048Kbit/s channels per Aggregate Interface.

The service will support both Aggregate to Single 2048Kbit/s working and Aggregate to Aggregate working.

3. Service Availability

The STM4c service is available where network capacity exists.

The STM4 Aggregate service is available throughout the UK (inland only) where network capacity exists.

4. Technical Specification

4.1 Service Presentation

The technical presentation is described in SIN 333, SDH Customer Interfaces At the STM-N level (where N=1,4,16)

The services are presented as an optical Single-Mode fibre connection conforming to ITU-T Recommendation G.957^[2] for SDH optical requirements. The optical fibre presentation at the UNI is conformant to BS EN 60825-1^[4] and BS EN 60825-2^[5] as a Class 1 Laser Product.

The physical presentation is via a FC type optical connector conforming to BS EN 186110:1994^[6]. The connector is Physical Contact (PC) polished. Non Return-to-Zero (NRZ) line coding is used as specified in ITU-T Recommendation G.957^[2].

The signal transmitted from the BT NTE is derived from a 1310nm wavelength long haul SDH class (L-1.1 as specified in ITU-T Recommendation G.957^[2]) optical transmitter; which has been attenuated by 10dB to provide a transmitted power range of between -10dBm and -15dBm (The 10dB attenuator is provided by BT on the NTE transmitter to ensure that the Network Terminal Equipment receiver is not saturated). The NTE receiver power range is between -10dBm and -34dBm.

The recommended configuration of the SDH Section and Path Overheads is given SIN333. Figure 1 highlights the difference between SDH Sections and SDH Paths.

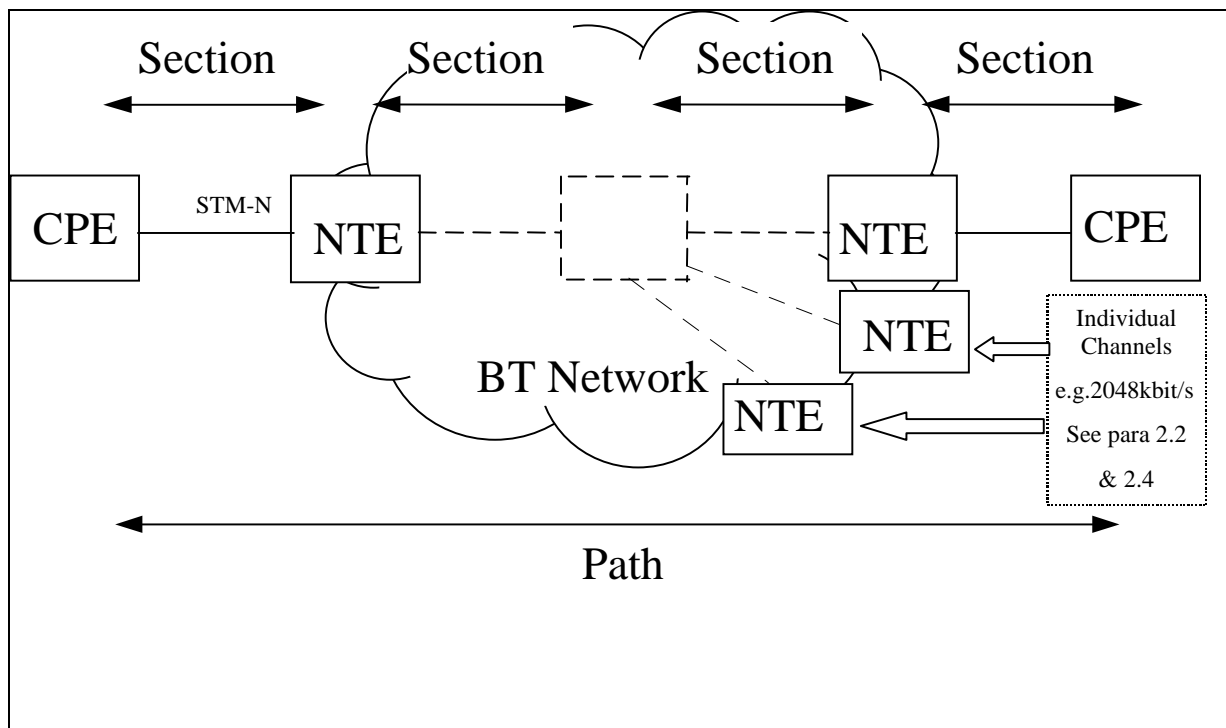

Figure 1 - Comparison of SDH Path vs. Section

4.2 Connection Characteristics

Connection characteristics are described in SIN 333, SDH Customer Interfaces At the STM-N level (where N=1,4,16).

4.3 Multiplex section protection (MSP)

Multiplex section protection (MSP) will provide a standby connection within the customer's premises. For STM4 services, this connection is optical. See SIN333 for technical details.

5. Further Information Contact Point

For enquiries concerning connection availability between particular sites and for further "sales and marketing" information on the MegaStream services, please contact your Account Manager or authorised dealer.

If you have enquiries relating to this document then please contact: help@sinet.bt.com

6. References

[1]	G.707	Network node interface for the Synchronous Digital Hierarchy (SDH)	1996	ITU-T
[2]	G.957	Optical interfaces for equipment's and systems relating to the synchronous digital hierarchy	1995	ITU-T
[3]	ETS 300 147	Transmission and Multiplexing (TM); Synchronous Digital Hierarchy (SDH); Multiplexing Structure.	1997	ETSI
[4]	BS EN 60825-1	Safety of Laser Products Part 1 Equipment classification	1994	British Standard
[5]	BS EN 60825-2	Safety of Laser Products Part 2 Safety of Optical fibre communications systems	1995	British Standard
[6]	BS EN 186110	Sectional Specification. Connector sets for optical fibre and cables Type FC	1994	British Standard

For further information or copies of referenced sources, please see document sources at <http://www.sinet.bt.com/usenum.htm#docsources>

7. Abbreviations

CCITT	Now known as ITU-T
ETS	European Telecommunication Standard
ETSI	European Telecommunications Standards Institute
ITU-T	International Telecommunication Union For Telecommunications (formerly CCITT)
NTE	Network Terminating Equipment
MSP	Multiplex Section Protection
SDH	Synchronous Digital Hierarchy
SIN	Suppliers' Information Note
TE	Terminal Equipment
UNI	User Network Interface
VC	Virtual Container

8. History

Issue 1	Nov 1999	First Issue
Issue 2.0	March 2001	Addition of MegaStream 2.4Gbit/s service options
Issue 2.1	June 2002	Removal of MegaStream 2.4Gbit/s service options
Issue 2.2	June 2003	Approval Requirements statement removed, information available via SINet Useful Contacts page.
Issue 2.3	March 2009	Noted that MegaStream 622 is withdrawn for new sale. Updated contact information. Minor editorial amendments.

-END-

We would be grateful if you would take a few minutes to complete an online customer satisfaction form at <http://www.sinet.bt.com/happy.htm>